

Drilling template for retrofitting the AIQ Detect sensor magnets for N-EUPEX and RUPEX Couplings.

1. **Please print this page on a DIN A4 sheet of paper**
Set "Actual size" in Adobe Reader when printing
2. **Cut out the required template along the black outlines**
Please check that the coupling type and size match the data on the respective template
3. **Glue the template onto the coupling according to the quick guide**
Check the correct positioning, the center line must be in the middle of the coupling gap
4. **Drill the two holes with the Flender drill according to the quick guide**
The Flender drill guarantees a drilling depth of 3 mm
5. **Insert the sensor magnets from the AIQ Detect packaging**
On one coupling side, the north pole must point upwards, and the south pole on the other side

The Flender coupling is now ready for use with the AIQ Detect. Please position the AIQ Detect according to the operating instructions.

Quick guide:

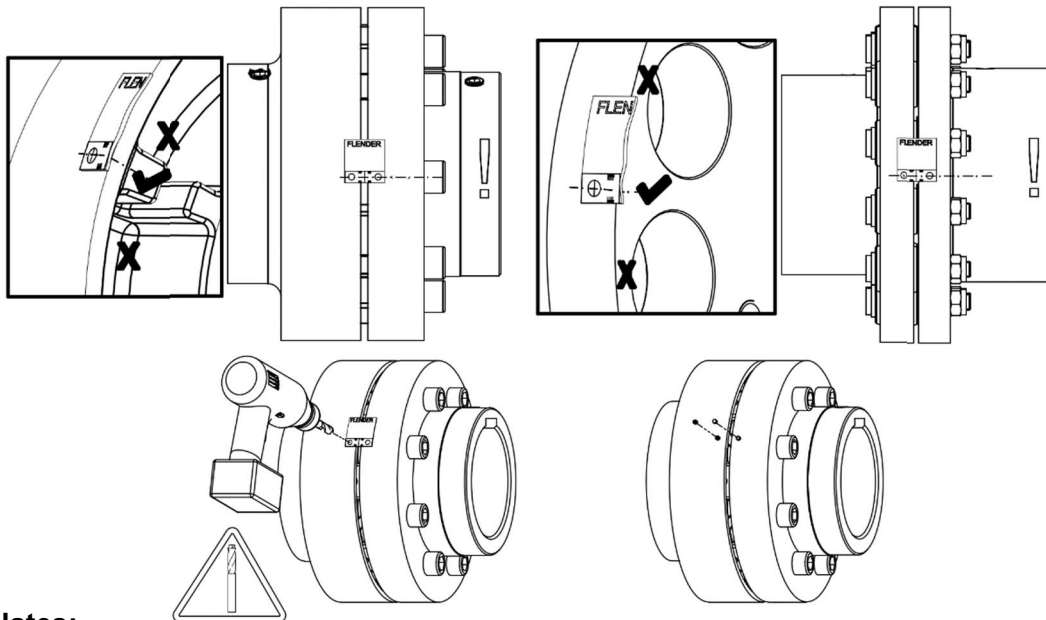

Templates:

